

USB-Seriell-ISO: a galvanically isolated USB to serial converter

Overview

The USB-Seriell-ISO is an easy to use USB to serial converter with galvanic isolation. The galvanic isolation provides protection for the PC against overvoltage and ground loops. Field of application: Test- and measurement systems, machines and PLCs with serial interface. The design is based on an USB chip from FTDI. FTDI offers driver support for all major operating systems. This makes the device compatible almost every PC systems with USB connection. Three variants are available, which differ in the Serial signal level: 3,3V, 5V or standard RS232 level. For diagnostic purposes, a LED is provided, which will flash during an ongoing data transmission. The USB-Seriell-ISO is USB powered and needs no external power supply.



Pin assignment

RS232-Side: 9pin DSUB male	
Pin Nr.	Assignment
2	Serial data input
3	Serial data output
5	GND
4,7	Control output (Optional)
6,8	Control input (Optional)
1	Optional supply for the serial port
9	NC



Please note: In this document Input and Output are always described from the converters point of view. NC: not connected

Technical Data (Summary)

Supply Voltage	DC 5V +/- 5%, typically 70mA via USB
Temperature Range	0°C to 40°C
Maximum Data Rate	115200Bd
Type of Insulation	Functional Isolation Insulation withstand voltage 2500V, Clearance 6,2mm, Creepage 7mm. It is the users duty to check if the insulation will fit for a certain safety level, e.g. reinforced insulation according EN60950 for working voltage up to 1000V for insulation between SELV circuit and mains voltage.
Driver Software Support	Virtual Com Port driver for Windows 98 to Windows 7(64) WHQL, Mac OS 8 to OS X, Linux and Windows CE.NET via www.ftdichip.com
USB Connection	USB Socket, 1m Cable USB B to USB A included
Housing, Measures	Ca. 63 x 48 x 18mm inclusive D-Sub male connector

Dipl. Ing. J. Freitag Elektronik u. Systeme
Sudbrackstraße 38
D-33611 Bielefeld – Germany
Tel. +49 (521) 2701093

Fax +49 (521) 2701094
Email: info@freitag-elektronik.de
www.freitag-elektronik.de

Configuration of Control Lines (RTS, DTR, CTS, DSR)

The isolation supports one control line output and one control line input.

The which control signal is used for your application can be selected via solder jumpers.

The jumpers are available after opening the housing of the device.

The jumpers are designated on the PCB with silk screen print.

Possible Control Line Configurations:

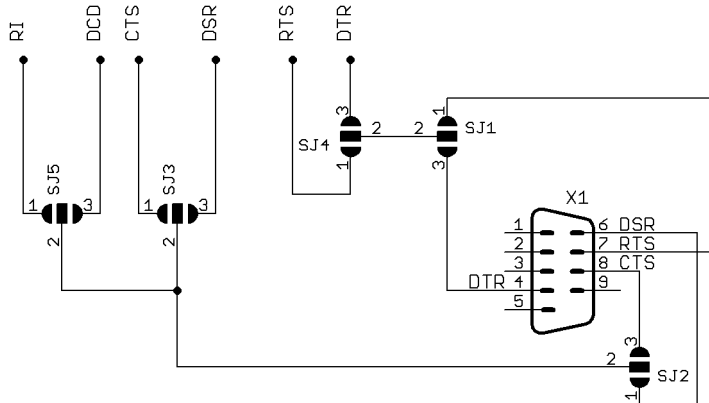

Variants and Order Codes

Order Code	Voltage Level of Serial Signal
USB-Seriell-ISO RS232	RS232 (-10V..+10V)
USB-Seriell-ISO TTL 5V	TTL Level 5V
USB-Seriell-ISO TTL 3V3	TTL Level 3,3V

This variants will not provide any pre-configured control lines. Please contact us, if you need a specific variant with pre-configured control lines.

Package List

- USB-Seriell-ISO xxx (xxx for the variant code)
- User Documentation
- 1m Cable USB B to USB A for connection to PC systems
- CD with drivers for Windows

Driver Software

For recent drivers you can also check the internet site <http://www.ftdichip.com/FTDrivers.htm>

For using the standard serial functions with a virtual COM Port, the VCP Drivers are needed. The D2xx Drivers will provide a DLL with more sophisticated functions for own software development.

Support

If you need a special configuration not listed here, you need an additional feature or you have certain technical requirements – please contact us by phone or email . We always try our best to support you with your demands.

Dipl. Ing. J. Freitag Elektronik u. Systeme
Sudbrackstraße 38
D-33611 Bielefeld – Germany
Tel. +49 (521) 2701093

Fax +49 (521) 2701094
Email: info@freitag-elektronik.de
www.freitag-elektronik.de